



BLASTER ELITE-90

www.qvee.com.au

90W Heavy Duty LED Worklight - Spot Beam

#QVWL90SHDE

DESCRIPTION

The QVEE 90W 'Blaster Elite' breaks the standards of worklights! Featuring the latest Osram® LED's producing a whopping 7,800 Lumens of Spot power consistently over your work zone. Equipped with a rugged mine spec mounting bracket and IP68/IP69K rated, vibration & shock resistant housing able to withstand even the harshest conditions. The ultimate reliable for 4WD's, mining and agricultural.

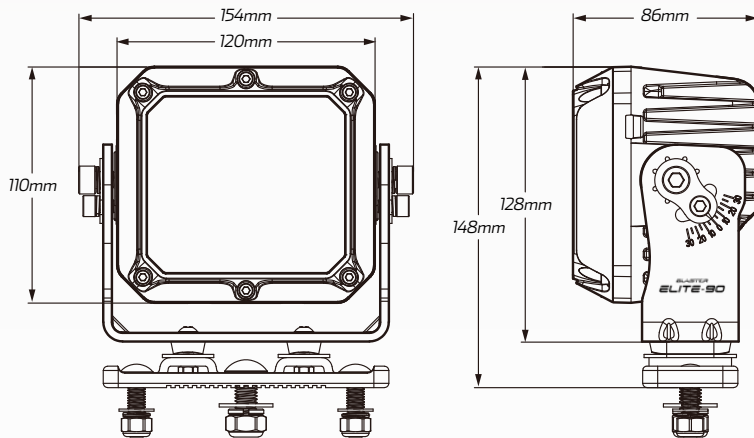

ACCESSORIES

- Mine Spec Mounting Brackets & Fittings



TECHNICAL SPECIFICATIONS

Voltage	• 10 - 32 Volt	Colour Temperature	• 5700 K
Wattage	• 90 Watt	Vibration Resistance	• 15G rms 24-2000Hz
IP Rating	• IP68/IP69K Rated	Shock Resistance	• 60G
Raw Lumens	• 7,800 Lumens	Housing Material	• Die-cast aluminium
Efficient Lumens	• 7,000 Lumens	Lens Material	• Polycarbonate Lens
LED Count	• 9 x 10W High Powered Osram® LED's	Dimensions	• 154mm L x 148mm H x 86mm D
Beam Coverage	• Spot Beam	Approvals	• EMC CISPRS 4, CE, RoHS, R10, R112

