



BLASTER ELITE-60

www.qvee.com.au

60W Heavy Duty LED Worklight - Spot Beam

#QVWL60SHDE

DESCRIPTION

The QVEE 60W 'Blaster Elite' Worklight elevates your work area, providing brilliant 5,200 Lumens of spot beam lighting through its high quality Osram® LED's. Accompanied with an IP68/IP69K rated housing which are vibration and shock resistant and a mine spec mounting bracket, you can guarantee that these worklight will always provide consistent illumination even in the harshest environments.

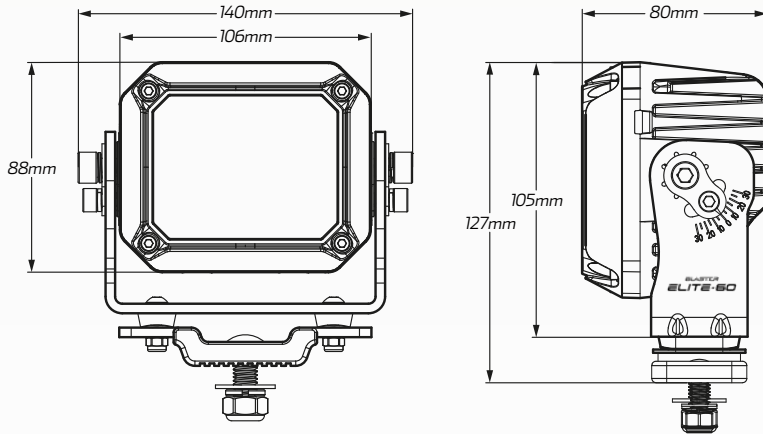

ACCESSORIES

- Mine Spec Mounting Brackets & Fittings



TECHNICAL SPECIFICATIONS

Voltage	• 10 - 32 Volt	Colour Temperature	• 5700 K
Wattage	• 60 Watt	Vibration Resistance	• 15G rms 24-2000Hz
IP Rating	• IP68/IP69K Rated	Shock Resistance	• 60G
Raw Lumens	• 5,200 Lumens	Housing Material	• Die-cast aluminium
Efficient Lumens	• 4,000 Lumens	Lens Material	• Polycarbonate Lens
LED Count	• 6 x 10W High Powered Osram® LED's	Dimensions	• 140mm L x 127mm H x 80mm D
Beam Coverage	• Spot Beam	Approvals	• EMC CISPRS 4, CE, RoHS, R10, R112

