



## BLASTER ELITE-40

www.qvee.com.au

## 40W Heavy Duty LED Worklight - Flood Beam

#QVWL40FHDE



### DESCRIPTION

The QVEE 40W 'Blaster Elite' Worklight is an excellent heavy duty entry. These lights utilise high quality optics and high powered Osram® LED producing 4,000 Lumens, ensuring that your work area is always well illuminated. Heavy duty aluminium housing with IP68/IP69K rating, vibration & shock resistant. The perfect companion of the more extreme avid 4 wheel drivers, Agricultural or site vehicles.

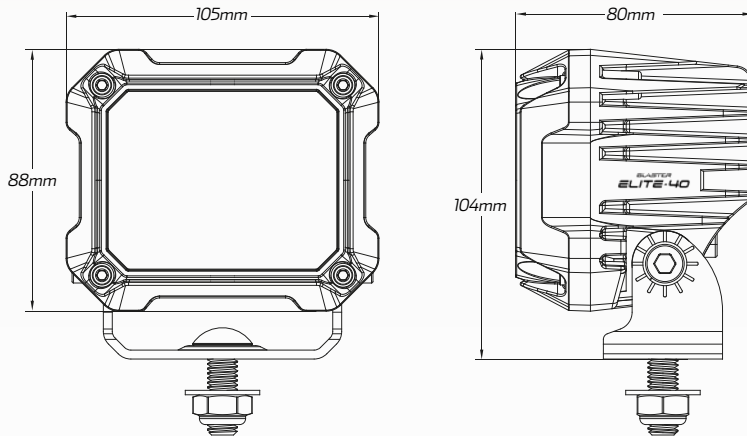

### ACCESSORIES

- Mine Spec Mounting Brackets & Fittings



### TECHNICAL SPECIFICATIONS

<b>Voltage</b>	• 10 - 32 Volt
<b>Wattage</b>	• 40 Watt
<b>IP Rating</b>	• IP68/IP69K Rated
<b>Raw Lumens</b>	• 4,000 Lumens
<b>Effective Lumens</b>	• 3,200 Lumens
<b>LED Count</b>	• 4 x 10W High Powered Osram® LED's
<b>Beam Coverage</b>	• Flood Beam
<b>Colour Temperature</b>	• 5700 K
<b>Vibration Resistance</b>	• 15G rms 24-2000Hz
<b>Shock Resistance</b>	• 60G
<b>Housing Material</b>	• Die-cast aluminium
<b>Dimensions</b>	• 105mm L x 104mm H x 80mm D
<b>Approvals</b>	• EMC CISPRS 4, CE, RoHS, R10, R112

### BEAM COVERAGE

