



## BLASTER ELITE-160

www.qvee.com.au

## 160W Heavy Duty LED Worklight - Spot Beam

#QVWL160SHDE

### DESCRIPTION

This 160W 'Blaster Elite' worklight is the marvel of lighting performance. Equipped with high quality Osram® LED's, these lights unleashes an extraordinary 13,800 Lumens of spot lighting across your work space. Vibration & shock resistant up to 60G, EMC CISPRS 4 rated. Accompanied with rugged IP69K rated housing & mine spec mounting bracket, these lights are ready to tackle even the most severe mining conditions.

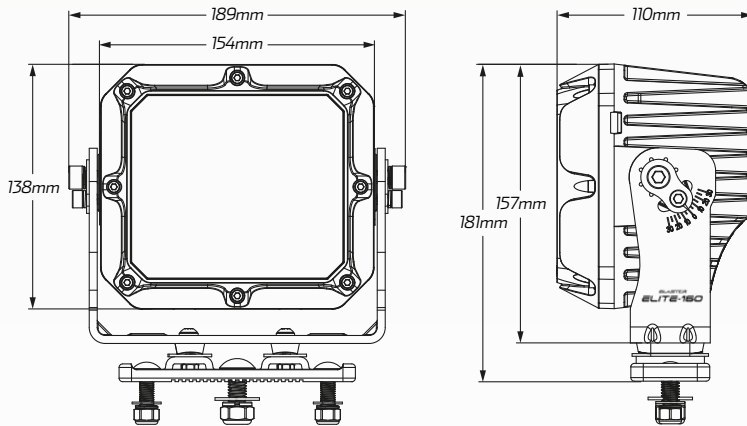

### ACCESSORIES

- Mine Spec Mounting Brackets & Fittings

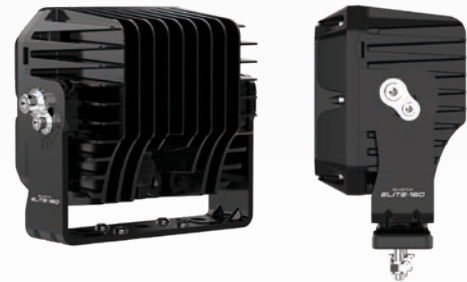

### TECHNICAL SPECIFICATIONS

<b>Voltage</b>	• 10 - 32 Volt	<b>Colour Temperature</b>	• 5700 K
<b>Wattage</b>	• 120 Watt	<b>Vibration Resistance</b>	• 15G rms 24-2000Hz
<b>IP Rating</b>	• IP68/IP69K Rated	<b>Shock Resistance</b>	• 60G
<b>Raw Lumens</b>	• 13,800 Lumens	<b>Housing Material</b>	• Die-cast aluminium
<b>Effective Lumens</b>	• 11,000 Lumens	<b>Lens Material</b>	• Polycarbonate Lens
<b>LED Count</b>	• 16 x 10W High Powered Osram® LED's	<b>Dimensions</b>	• 189mm L x 181mm H x 110mm D
<b>Beam Coverage</b>	• Spot Beam	<b>Approvals</b>	• EMC CISPRS 4, CE, RoHS, R10, R112

### BEAM COVERAGE

