



BLASTER ELITE-160

www.qvee.com.au

160W Heavy Duty LED Worklight - Flood Beam

#QVWLI160FHDE



ACCESSORIES

- Mine Spec Mounting Brackets & Fittings

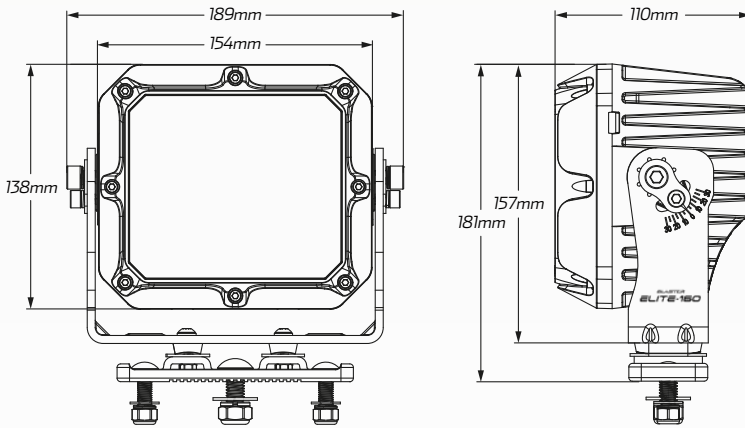
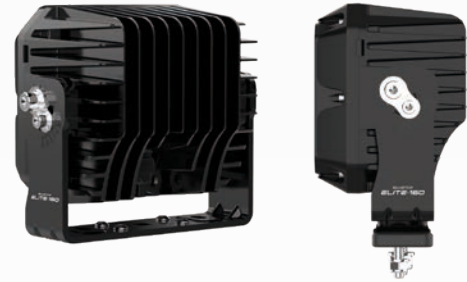

TECHNICAL SPECIFICATIONS

Voltage	• 10 - 32 Volt
Wattage	• 160 Watt
IP Rating	• IP68/IP69K Rated
Raw Lumens	• 13,800 Lumens
Effective Lumens	• 11,000 Lumens
LED Count	• 16 x 10W High Powered Osram® LED's
Beam Coverage	• Flood Beam
Colour Temperature	• 5700 K
Vibration Resistance	• 15G rms 24-2000Hz
Shock Resistance	• 60G
Housing Material	• Die-cast aluminium
Dimensions	• 189mm L x 181mm H x 110mm D
Approvals	• EMC CISPRS 4, CE, RoHS, R10, R112

BEAM COVERAGE

