



BLASTER ELITE-120

www.qvee.com.au

120W Heavy Duty LED Worklight - Spot Beam

#QVWL120SHDE



DESCRIPTION

The QVEE 120W 'Blaster Elite' reliably enhances your vision with up to 10,800 Lumens of spot beam lighting. These Worklights are designed to withstand the harshest Agricultural, Mining and Industrial applications through IP69K Rated housing and Mine Spec mounting bracket. Vibration and shock resistant up to 60G, makes these lights dependable at even the harshest 4WD, agricultural and mining environments.

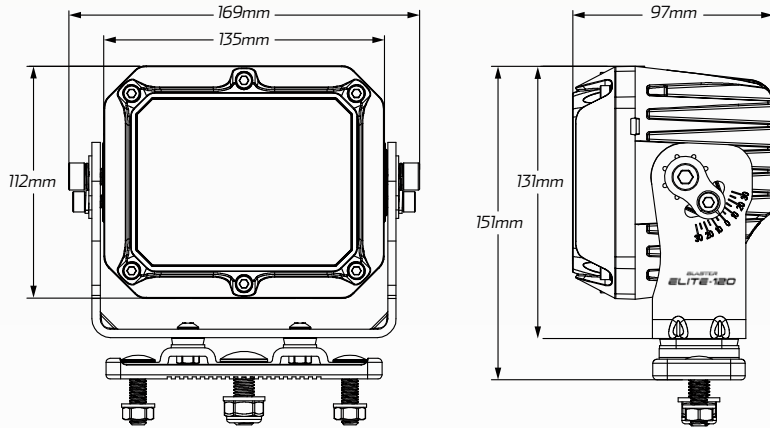

ACCESSORIES

- Mine Spec Mounting Brackets & Fittings



TECHNICAL SPECIFICATIONS

Voltage	• 10 - 32 Volt	Colour Temperature	• 5700 K
Wattage	• 120 Watt	Vibration Resistance	• 15G rms 24-2000Hz
IP Rating	• IP68/IP69K Rated	Shock Resistance	• 60G
Raw Lumens	• 10,800 Lumens	Housing Material	• Die-cast aluminium
Effective Lumens	• 9,000 Lumens	Lens Material	• Polycarbonate Lens
LED Count	• 12 x 10W High Powered Osram® LED's	Dimensions	• 169mm L x 151mm H x 97mm D
Beam Coverage	• Spot Beam	Approvals	• EMC CISPRS 4, CE, RoHS, R10, R112

