



## BLASTER 120W Heavy Duty LED Worklight - Flood Beam

www.qvee.com.au

#QVWL120MFHD

### DESCRIPTION

The 'Blaster' series are Heavy Duty Worklights specifically designed for harsh environments like Agricultural & Mining. These 120W 'Blaster' Heavy Duty Worklights are powered by 12 x 10W high intensity Osram® LED's producing a massive 12,000 Lumens of bright 5700K lighting. Features an IP69K rated housing & ultra heavy duty mounting bracket, Class 4 EMC/EMI protection and in-built Deutsch connector.

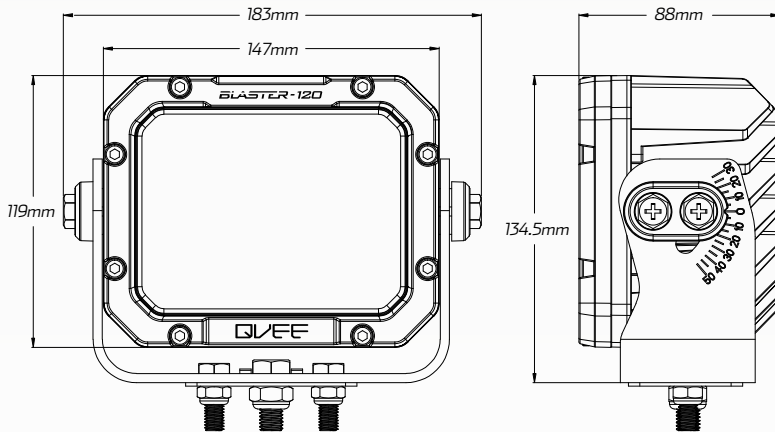

### ACCESSORIES

- Heavy Duty Mounting Brackets & Fittings



### TECHNICAL SPECIFICATIONS

Voltage	• 9 - 32 Volt
Wattage	• 120 Watt
IP Rating	• IP69K Rated
Raw Lumens	• 12,000 Lumens
Efficient Lumens	• 10,200 Lumens
LED Count	• 12 x 10W High Powered Osram® LED's
Beam Coverage	• Flood Beam
Colour Temperature	• 5700 K
Vibration Resistance	• Up to 30G
Housing Material	• ADC 12 Aluminium Housing
Lens Material	• Polycarbonate Lens
Dimensions	• 183mm L x 134.5mm H x 88mm D
Approvals	• EMC/EMI Rating: CISPR 25 - Class 4

### BEAM COVERAGE

