



## BLASTER ELITE-120

www.qvee.com.au

## 120W Heavy Duty LED Worklight - Flood Beam

#QVWL120FHDE

### DESCRIPTION

The QVEE 120W 'Blaster Elite' reliably enhances your vision with up to 10,800 Lumens of flood beam lighting. These Worklights are designed to withstand the harshest Agricultural, Mining and Industrial applications through IP69K Rated housing and Mine Spec mounting bracket. Vibration and shock resistant up to 60G, makes these lights dependable at even the harshest 4WD, agricultural and mining environments.

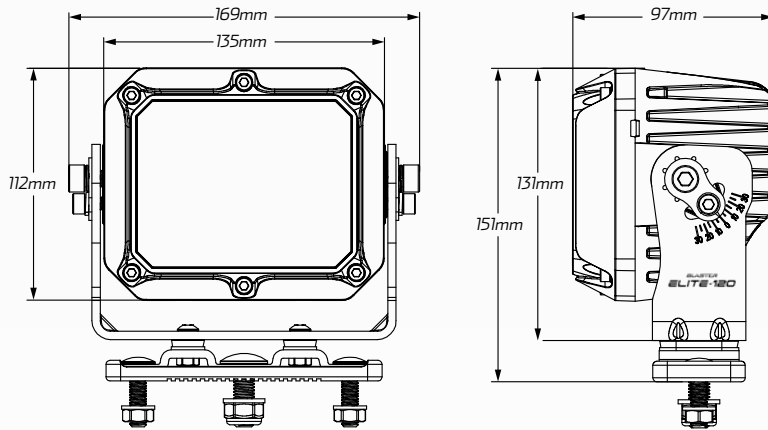

### ACCESSORIES

- Mine Spec Mounting Brackets & Fittings



### TECHNICAL SPECIFICATIONS

Voltage	• 10 - 32 Volt
Wattage	• 120 Watt
IP Rating	• IP68/IP69K Rated
Raw Lumens	• 10,800 Lumens
Effective Lumens	• 9,000 Lumens
LED Count	• 12 x 10W High Powered Osram® LED's
Beam Coverage	• Flood Beam
Colour Temperature	• 5700 K
Vibration Resistance	• 15G rms 24-2000Hz
Shock Resistance	• 60G
Housing Material	• Die-cast aluminium
Dimensions	• 169mm L x 151mm H x 97mm D
Approvals	• EMC CISPRS 4, CE, RoHS, R10, R112

### BEAM COVERAGE

