

Male L-Type Fusible Link

#QVLBF

www.qvee.com.au

DESCRIPTION

The QVLBF series is a 32V DC L-Type fusible link with bent male terminals. Features element window. RoHS approved. Suitable for all automotive applications.

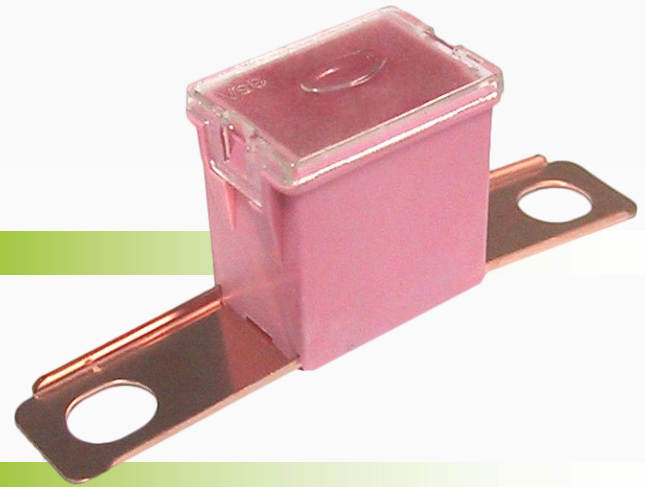

TECHNICAL SPECIFICATIONS

I.R.	• 1000A at 32V DC
Voltage	• 32V DC
Approvals	• RoHS Approved
Dimensions	• 62.0mm W x 15mm D x 21mm H

Time Characteristic % of Amp Rating	Opening Time	
	Min. Time	Max. Time
100%	• 100 Hours	--
200%	• 5 Seconds	• 60 Seconds
350%	• 0.2 Seconds	• 7 Seconds
600%	• 0.04 Seconds	• 1 Seconds

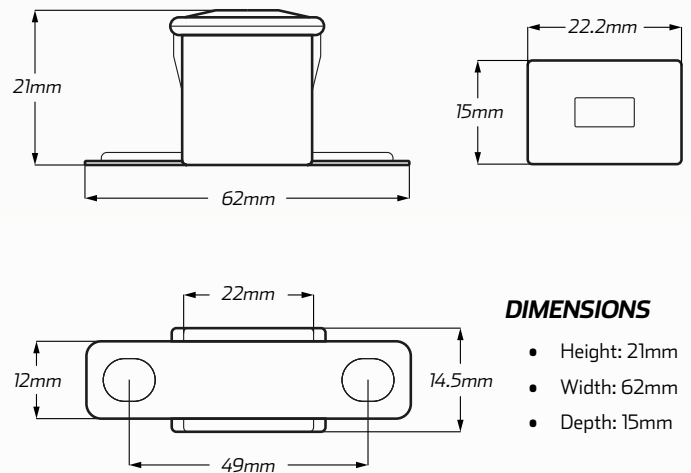

DIMENSIONS

- Height: 21mm
- Width: 62mm
- Depth: 15mm

PART NUMBERS

Part Number.	Amperage	Colour	Description
QVLBF030	• 20 Amp	• Pink	• 20 Amp pink L-Type fusible link with bent male terminals
QVLBF040	• 30 Amp	• Green	• 30 Amp green L-Type fusible link with bent male terminals
QVLBF050	• 40 Amp	• Red	• 40 Amp red L-Type fusible link with bent male terminals
QVLBF060	• 50 Amp	• Yellow	• 50 Amp yellow L-Type fusible link with bent male terminals
QVLBF080	• 60 Amp	• Black	• 60 Amp black L-Type fusible link with bent male terminals
QVLBF100	• 100 Amp	• Blue	• 100 Amp blue L-Type fusible link with bent male terminals
QVLBF120	• 120 Amp	• Grey	• 120 Amp grey L-Type fusible link with bent male terminals